



**Weight**  
Operation weight:  
approximately 175 tons

**Working height / reach**  
Maximum height: 49 mtr.  
Maximum reach: 30 mtr.

**STC HD 160D**



## It starts at the base:

Demolition at great height requires great precision and concentration from the operator: small movements at ground level are magnified at 40, 50, 60 meters height: Therefore, the rigidity of the machine itself is just as important as the smoothness of its controls. Rigidity is provided by custom built heavy duty frames. These important properties makes an STC HD-line machine easy to control, resulting in less operator fatigue, which pays off in more productive workdays.

## Undercarriage Quick Connect

To increase the stability STC has developed a new generation of heavy duty demolition undercarriages, the Undercarriage Quick Connect (UQC). These minimize operator fatigue due to their high stiffness and robustness, yet easy to disassemble into manageable sections all within the 3.5m transport width limit. The undercarriages are equipped with hydraulic outriggers that can fold out and lift the machine of the ground. Then the machine can disassemble its own tracks and place them on trailers using an integrated winch system.

To ensure trouble free operation in shoreline works such as dredging, breaker construction or shipwreck demolition, the locking pins are hardened and chrome plated and slide in hardened and nitrated bushings with grooves. The grooves distribute grease and ensure that foreign particles can evade so they do not scratch and jam the pins.

Whether your business is at great height downtown, reaching out on the shores, or ripping up quays underwater, the STC UQC gets you easily on any jobsite and provides a stable, durable and universally suitable base to support your large demolition and infrastructural jobs.

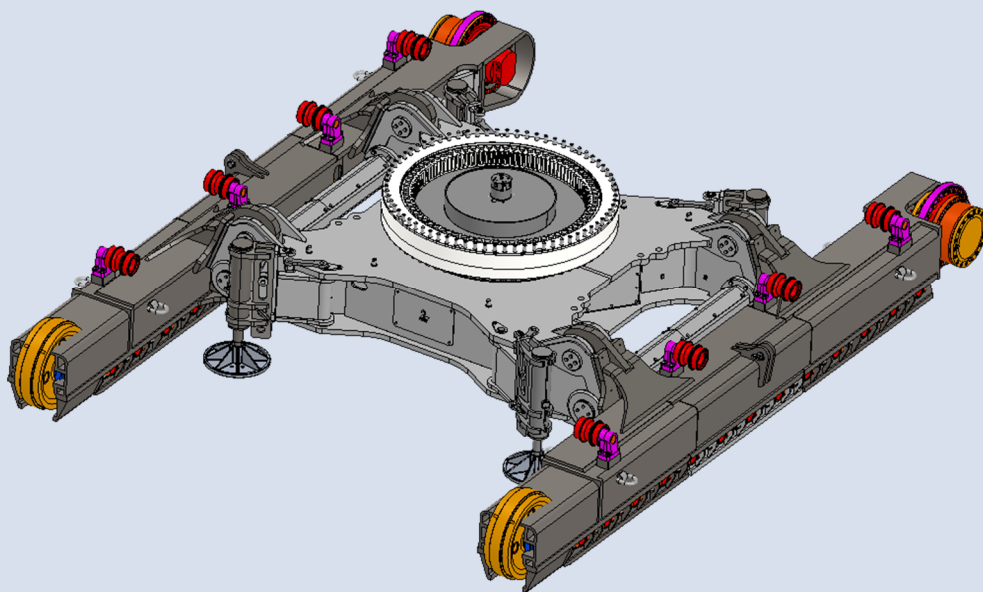



## Upper frame

Industrial demolition is the most demanding line of work for an excavator; the pounding of heavy hydraulic hammers transmitting their vibrations to the base machine, big scrap shears throws them off balance, and trying to pry loose foundation substructures will test the limits of the machine.

The standard upper frame is replaced by a STC custom designed upper frame, far exceeding the original design strength of the standard frame. The STC frame is designed for the optimal rigidity to carry larger ballasts, yet dampen any vibration of the tools on the front end. This to maximize the lifespan of the frame itself, as well as the components installed on it.

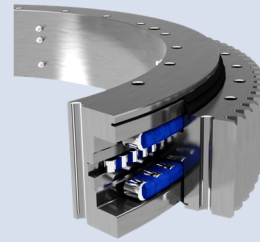

## *Slew bearing*

STC uses a custom made triple row roller bearing on all HD models, that are designed to last, even in the most demanding load set. The slew bearing provides stability to ensure a low but even wear and ample bolts are used to connect the bearing to the frames. Six greasing lines are fitted per roller row, which are centered to a common lubrication block.

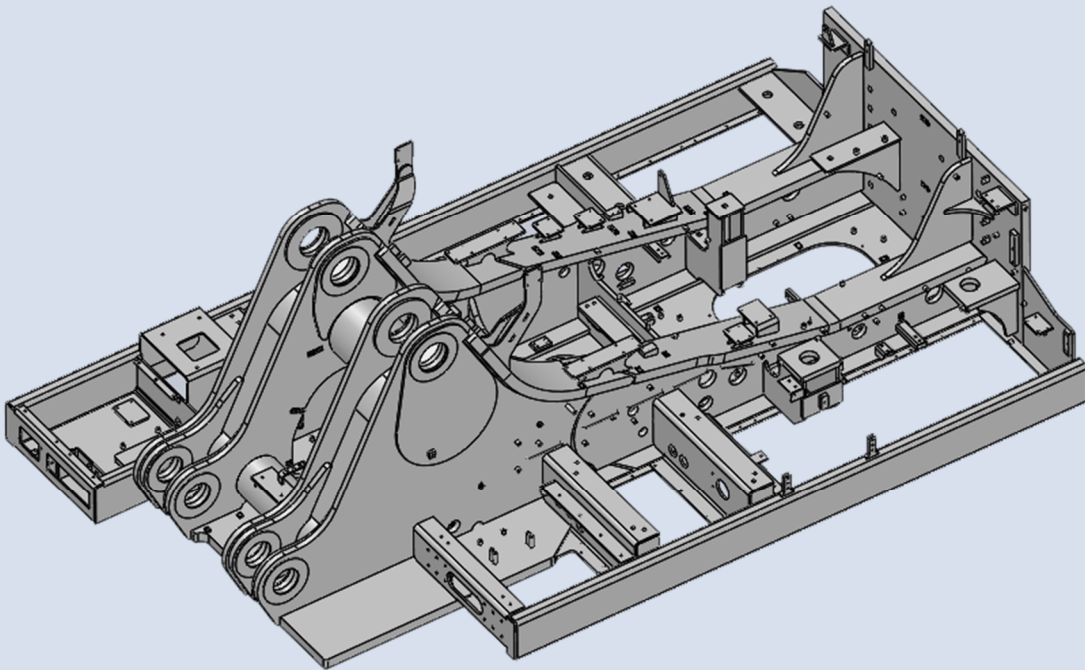



### *FOPS*

The impact energy of a falling object increases exponentially with increased height. Therefore, STC designed FOPS cages that exceed the ISO 6165 FOPS standard and match the working height of its current demolition machines. When an object falls down, there is no need to panic. The safest place will then be in the cabin under the STC safety cage. To ensure perfect visibility, each slat is angled individually towards the operators eye level so that the % of sight of an STC heavy duty demolition cage is no less than the standard excavator FOPS cages.

### *Cabin tilt, lift*

STC has built cab visibility improvement solutions since its inception. There are multiple solutions available like: Tilt cabins for high reach demolition, cabin lifts to look down over the edge of a construction pit or a combination of both, to ensure maximum versatility. Even on large machines that work in the horizontal plane, cab elevation increases the overview over the jobsite for the operator, enabling more precise and safe work with less fatigue. Armoured front glass is standard on our HD line, where the roof window is enlarged for extra comfort for the operator. A window wiper with parallel arm is standard as well.





## Front

Our booms are designed based on 30 years of experience, combined with the relevant scientific research on metal fatigue and metal processing. Finite Element Analysis is used to gain insight. STC booms are designed to last the lifetime of the machine, though it is not uncommon for customers to buy a new base machine, and reuse the existing STC booms.

Multiple booms are available with different length for the STC HD 160D

- High Reach Demolition 49 m
- High Reach Demolition 45 m
- Triple Tool Carrier 28 m
- Triple Excavation 24 m
- Triple 19 m

The STC HD line comes standard with a Boom Quick Connect (BQC). This ensures easy disassembly for transport, but also makes it possible to utilize multiple configurations. It is possible to use a high reach demolition boom or a triple boom in several reach and tool weight

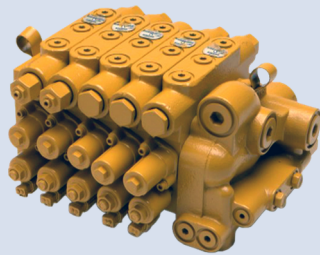

## Hydraulics

STC expands the main hydraulic valves, preferably with additional sections from the OEM. Smaller functions such as BQC pins are controlled by standardised industrial Cetop valves. Due to the increasing complexity of hydraulic systems, you cannot just plug in any valve section. With decades of experience with system modifications, we install the system extension with regard to minimal power loss and heat generation and the best controllability.

configurations. These can be combined with an extension piece, or even a long reach excavating boom, or a material handler boom can be fitted. All these configurations fit on the same base machine due to the use of the BQC. The customer can order the machine with the different front configurations or maybe even order one later when another configuration is needed.

STC has been one of the pioneers in BQC systems. Its current version incorporates a lot of field experience, which makes it one of the most durable systems in the market. Hollow pins with small hydraulic cylinder inside are mounted on the boom. The BQC pins are hardened and chromed and the nitrated bushings with grease grooves provide very high wear resistance, ensuring a lasting tight fit. The in-pin design provides a clean look because the cylinders are not visible on the outside. This also minimises the risk of damage during work or transport.



## Dust suppression (optional)

STC dust suppression systems consist of a hydraulically driven high pressure water pump, pushing water through stainless steel water lines mounted on the boom. Pressure washer nozzles are mounted on each side of the stick, to atomize water in the working area. A large filter is installed to clean the water when no domestic water supply is available. To prevent cavitation damage from insufficient water supply to the pump, the system is monitored by a pressure switch that switches off the pump when water pressure in the supply line drops below 0.5 bar.



### *Load Moment Indicator*

The machine can be equipped with a Load Moment Indicator (LMI), which recognises the assembled boom configuration by individual ID codes of each inclination sensor. This ensures that operators have a clear indication of where the stability limit is, so they can take the machine to its limits without taking undue risks. Because boom parts are recognised by the LMI system, hydraulic joystick and valve sensitivity can be automatically changed, to get the correct speed and feel whether you have the high reach demolition boom attached to work controlled at great height, or that a short triple boom is mounted to dig up concrete slabs at full power.

### *Service*

Regular maintenance can be done by local Cat technicians as all regular service parts are identical to Cat parts. STC wear parts can be supplied to the local Cat dealer for installation. But when a complex technical failure occurs, STC specialists can provide backup worldwide to get you back on the job.

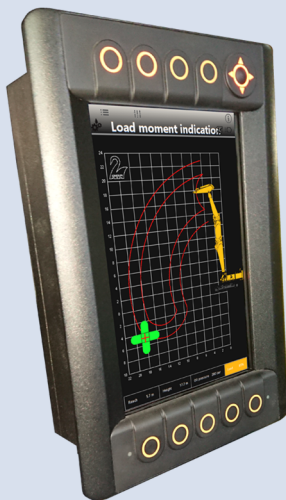



#### ENGINE:

Engine model	Cat C18	
Engine Power – ISO 9249	404 kW	542 hp
Engine Power – ISO 14396	405 kW	543 hp
Bore	145 mm	6 in
Stroke	183 mm	7 in
Displacement	18.1 L	1,105 in <sup>3</sup>

#### HYDRAULIC SYSTEM:

Main System – Maximum Flow – Implement	1064 L/min (x2 pumps)	281 gal/min
Maximum Pressure – Equipment – Implement	37 000 kPa	5,366 psi
Maximum Pressure – Travel	35 000 kPa	5,076 psi
Maximum Pressure – Swing	31 000 kPa	4,496 psi

#### SWING MECHANISM:

Swing Speed	6.3 rpm	
Maximum Swing Torque	362 kN·m	267,333 bf-ft

#### WEIGHTS:

Operating Weight	175 000 kg	386 000 lb
------------------	------------	------------

#### SERVICE REFILL CAPACITIES:

Fuel Tank	1220 L	322 gal
Cooling System	71 L	19 gal
Engine Oil (with filter)	67 L	18 gal
Swing Drive	24 L	6 gal
Final Drive (each)	20 L	5 gal
Hydraulic Tank (including suction pipe)	650 L	172 gal
DEF Tank	80 L	21 gal

#### DIMENSIONS:

Shipping Height (top of cab)	3250 mm	10'8"
Tail Swing Radius	5400 mm	17'9"
Track Length	8400 mm	27'7"
Track Length to Center of Rollers	7050 mm	23'2"
Track Gauge	5110 mm	16'9"

# STC HD 160D

5-1673-101

## HRD 49 mtr.

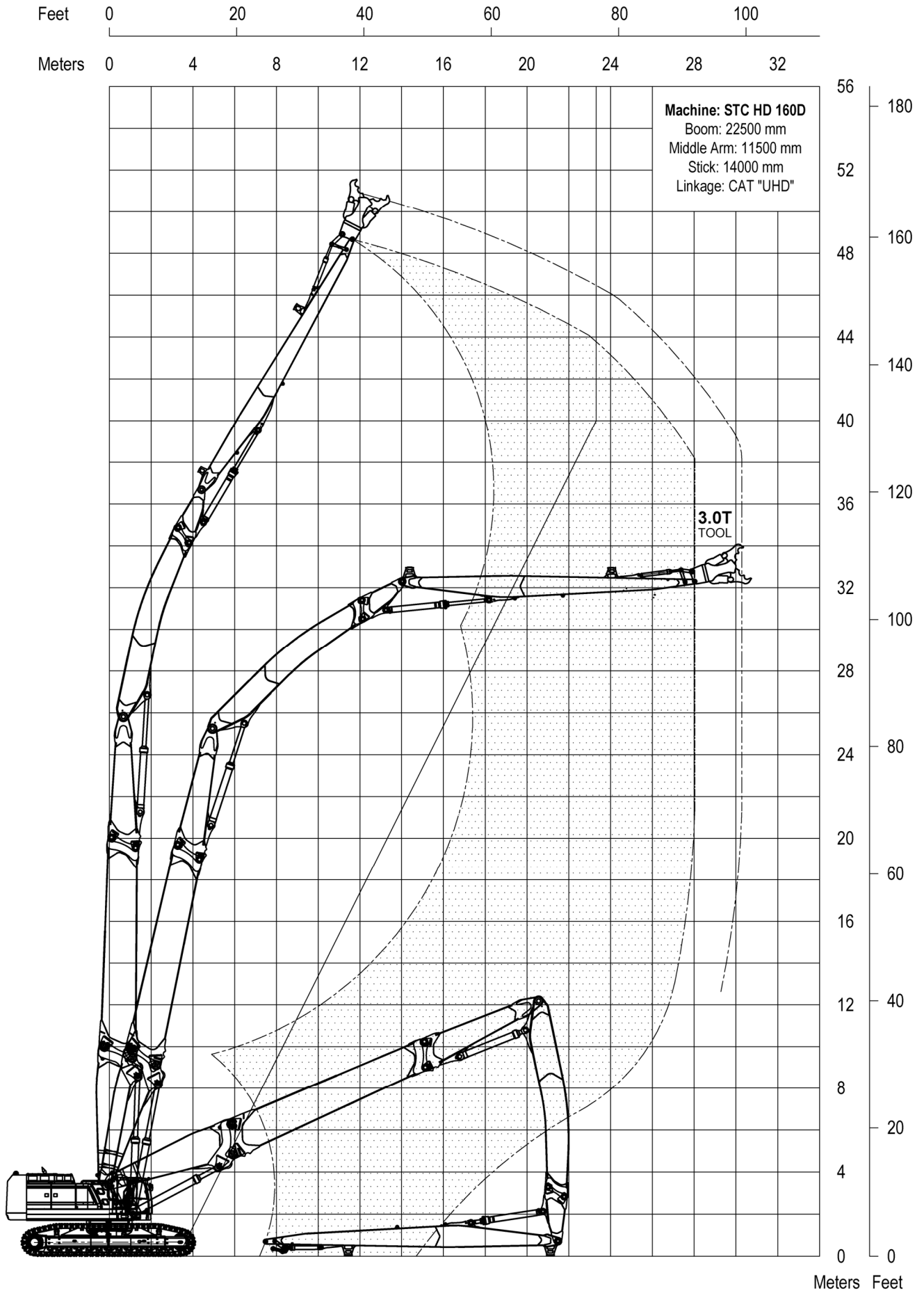



# STC HD 160D

5-1673-201

## HRD 45 mtr.

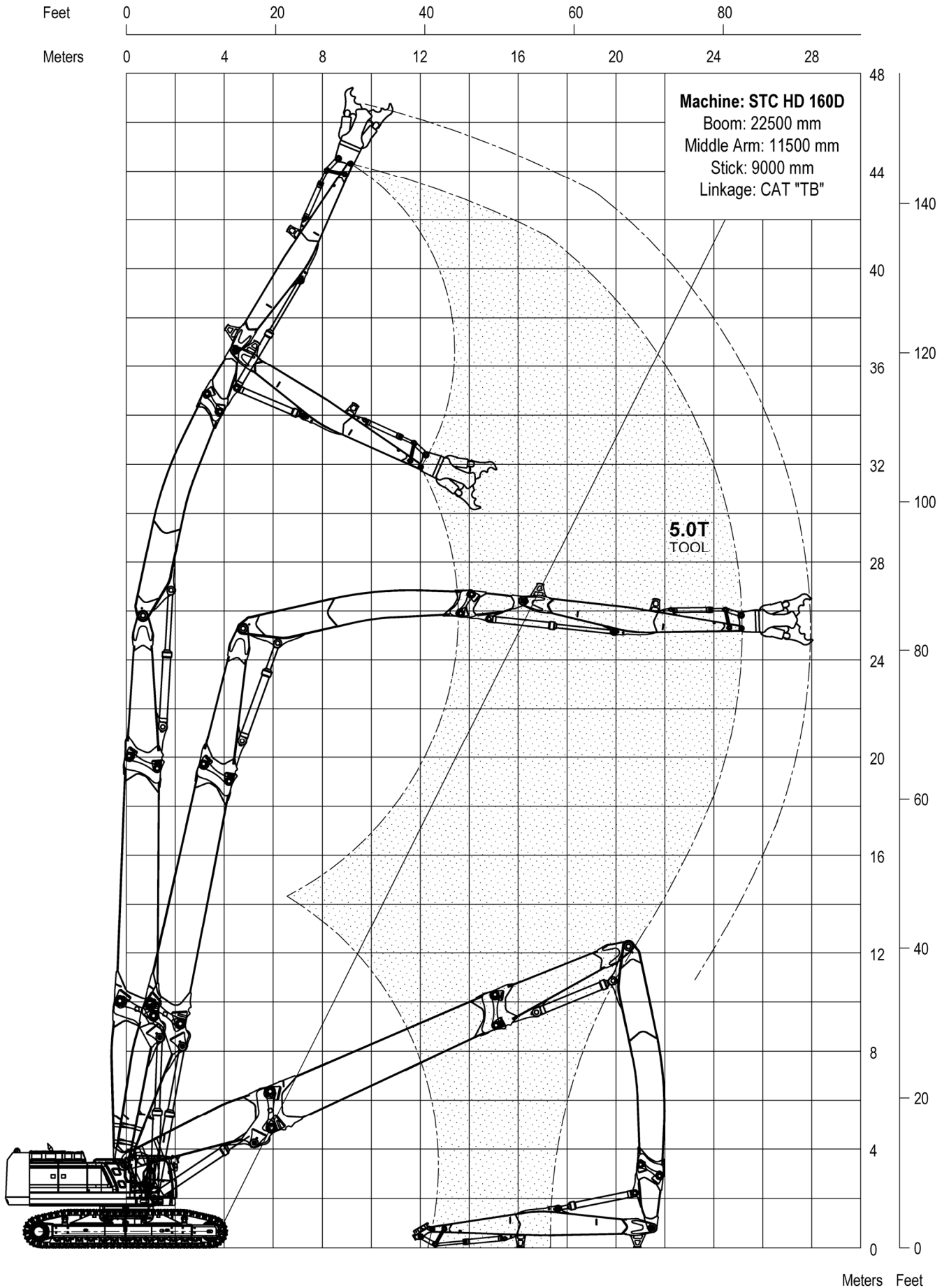

# STC HD 160D

5-1673-301

## Triple 28 mtr.

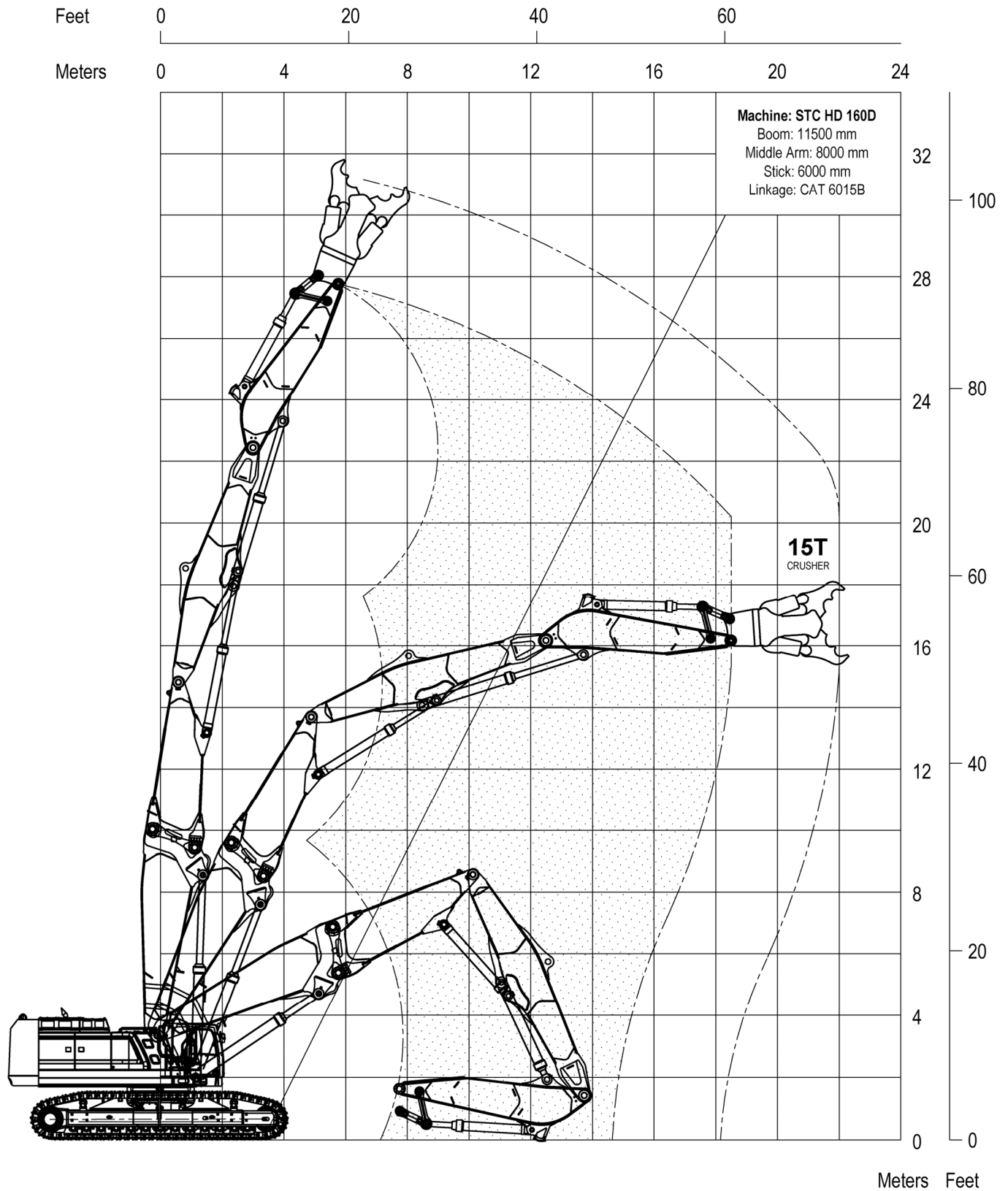

# STC HD 160D

5-1673-401

## Triple 24 mtr.

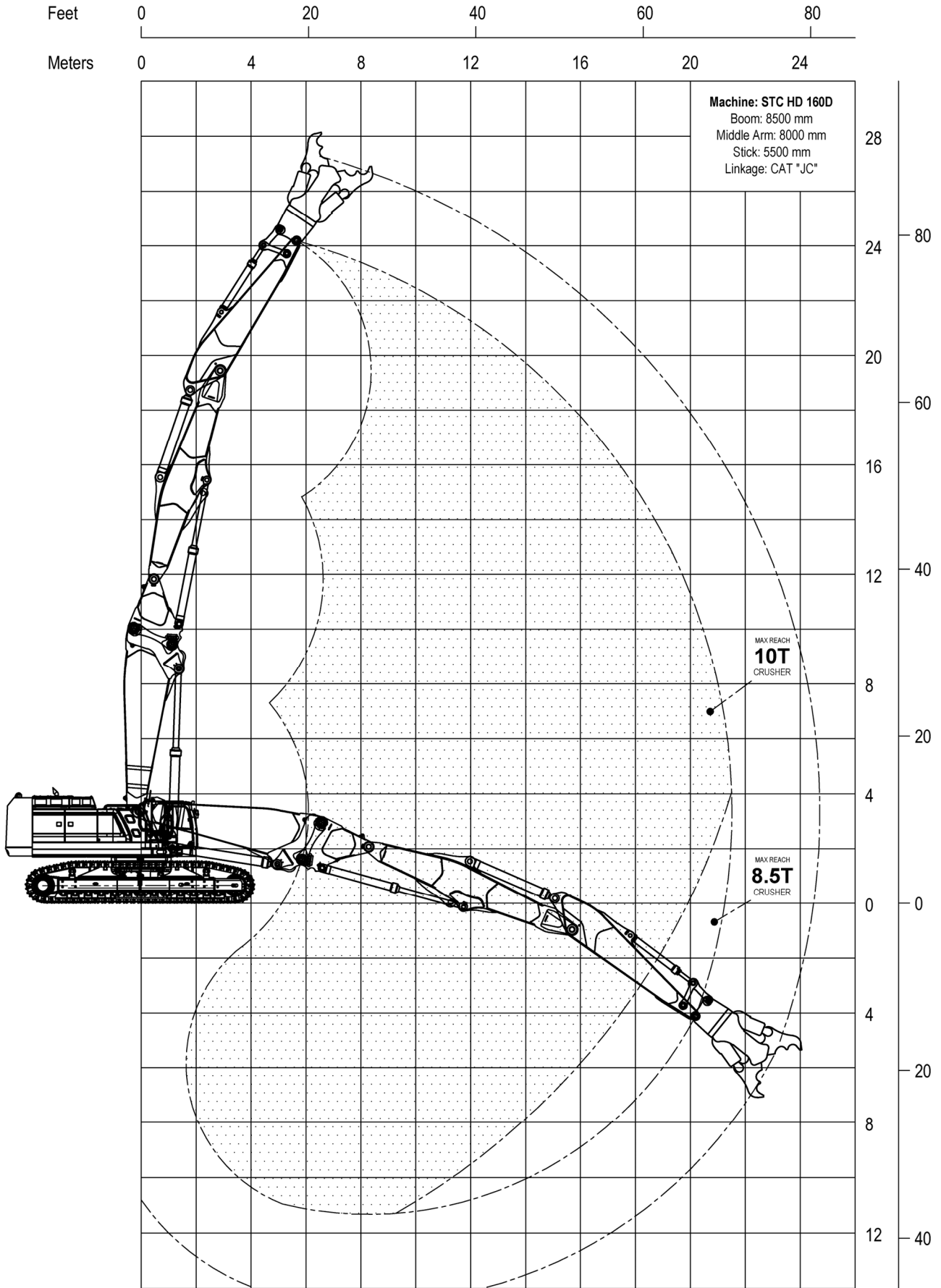

Meters Feet

# STC HD 160D

5-1673-501

## Triple 19 mtr.

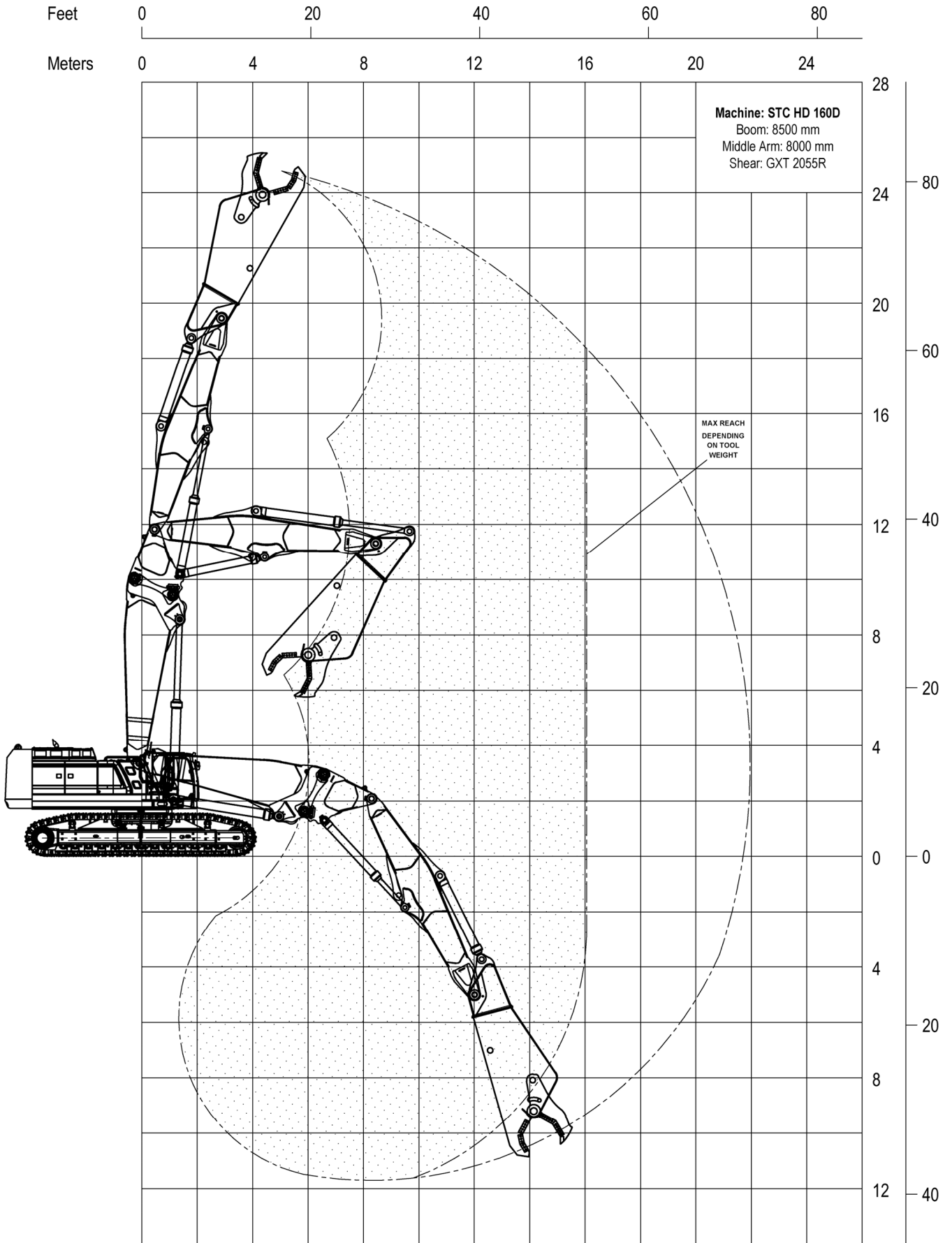

Meters Feet

## Configurations

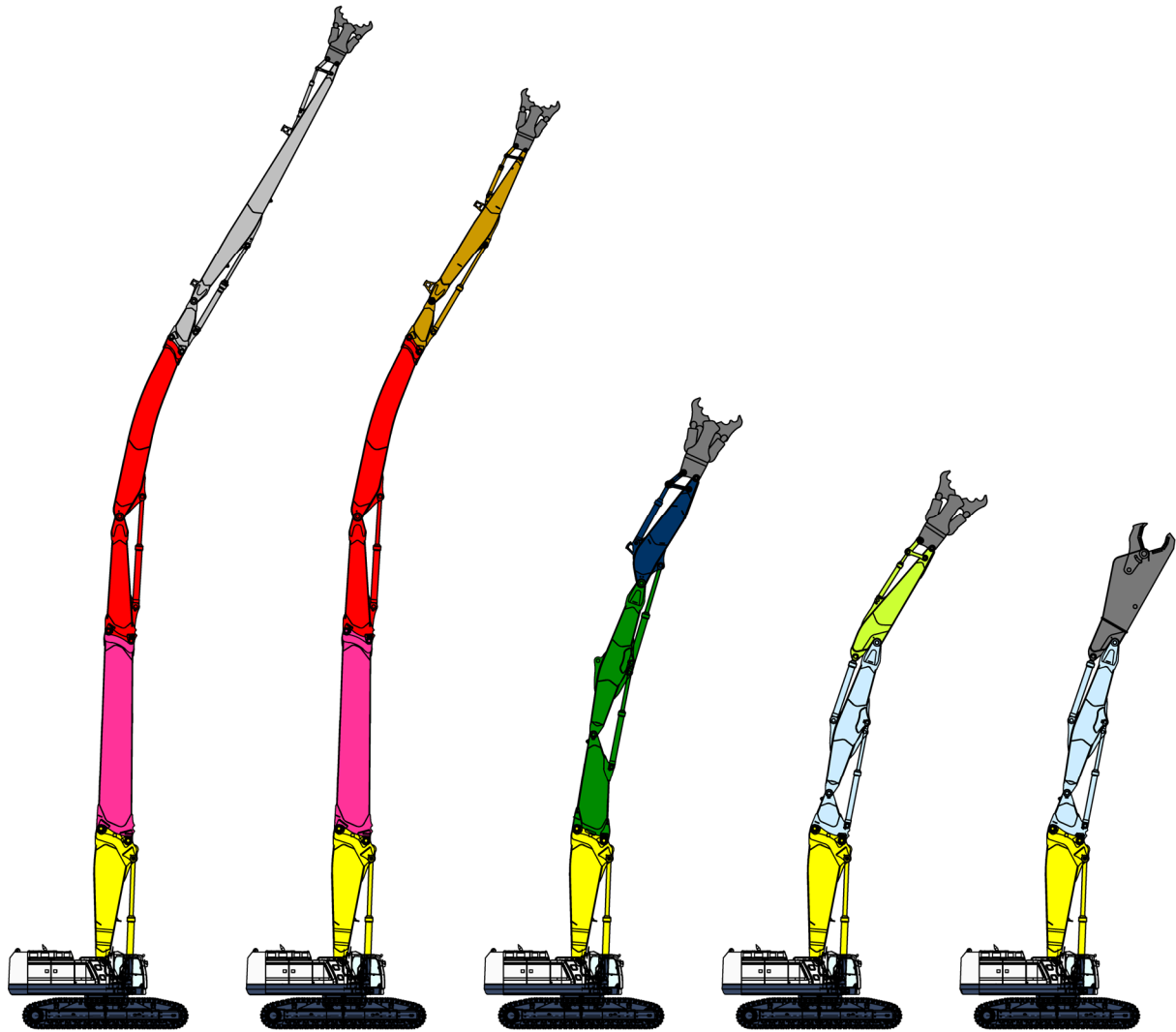

49 MTR.  
HRD

45 MTR.  
HRD

28 MTR.  
TRIPLE

24 MTR.  
TRIPLE

19 MTR.  
TRIPLE

HRD Stick 14000mm	●				
HRD Stick 9000mm		●			
HRD Middlearm	●	●			
Extension 10000mm	●	●			
Triple Stick 6000mm			●		
Triple Long			●		
Triple Stick 5500mm				●	
Triple Short				●	●
Stubboom	●	●	●	●	●
Toolweight	3T / 6600 lb Crusher 2.4T / 5300 lb Shear	5T / 11000 lb Crusher 4T / 8800 lb Shear	15T / 33100 lb Crusher 12T / 26500 lb Shear	10T / 22000 lb Crusher 8T / 17600 lb Shear	~20T/25T Shear ~44000/55000 lb Shear

## Transport table

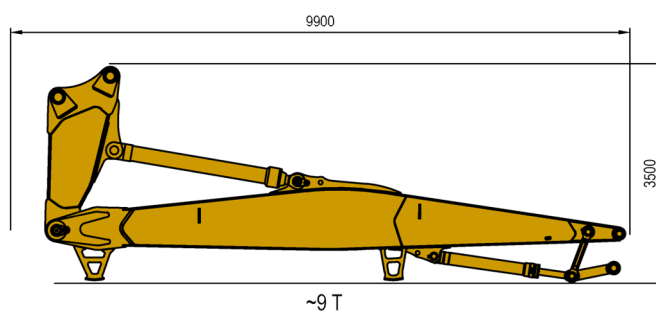
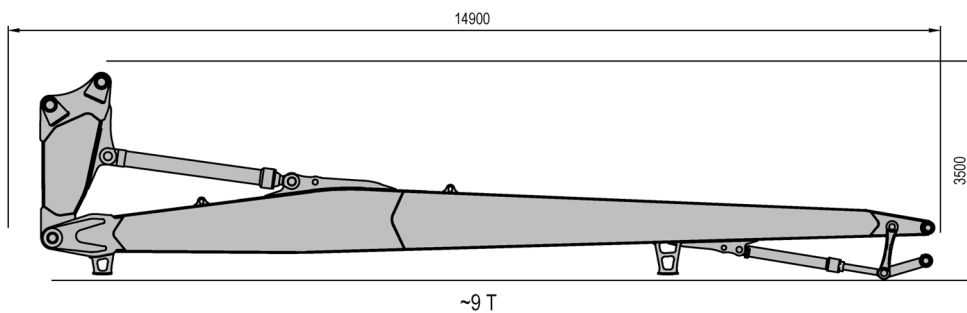
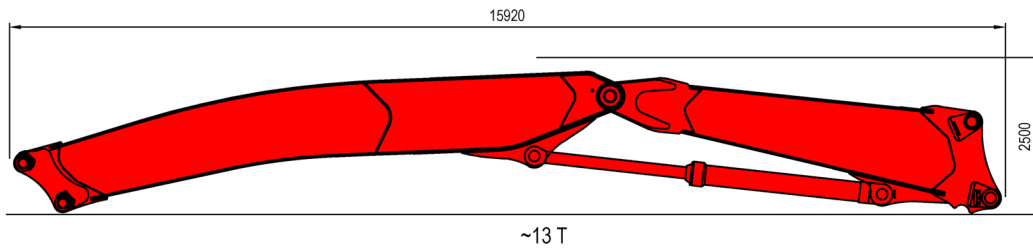
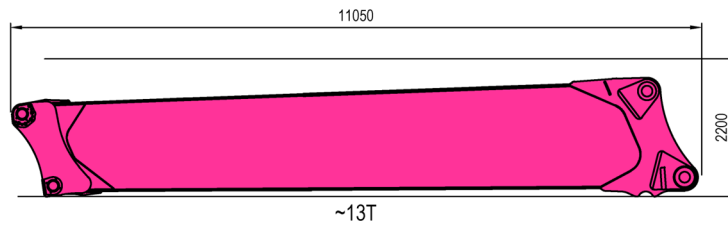
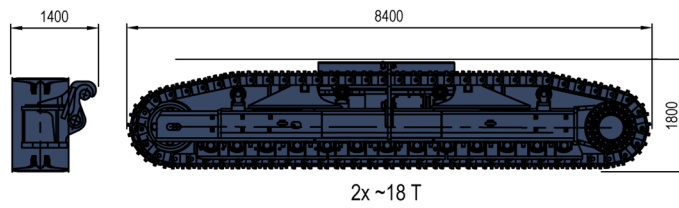
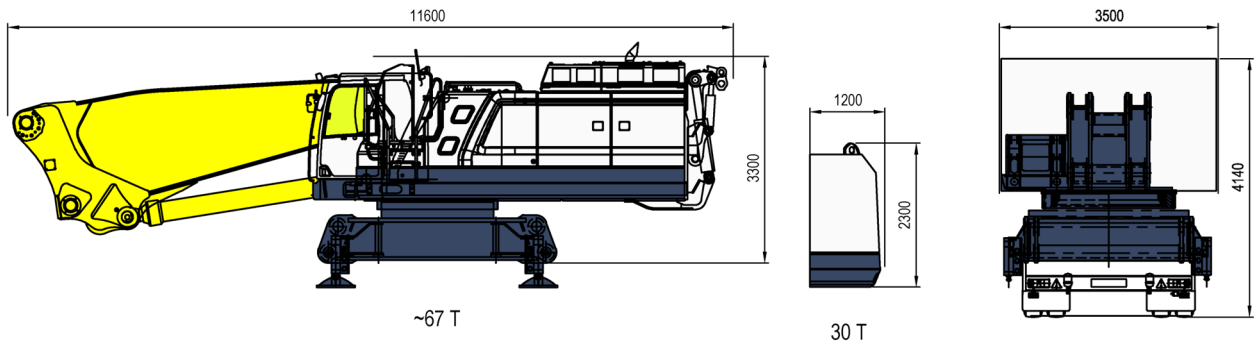

## Transport Table

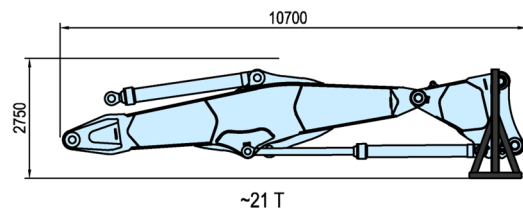
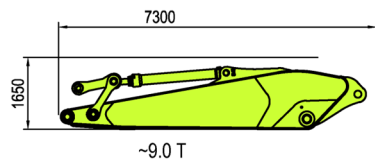
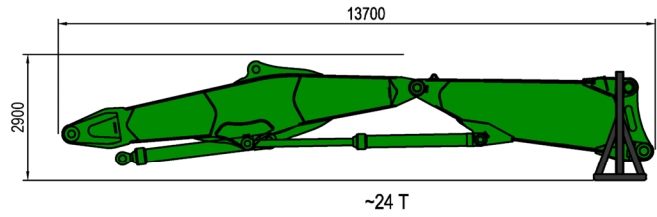
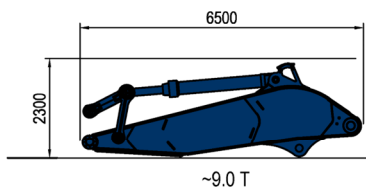
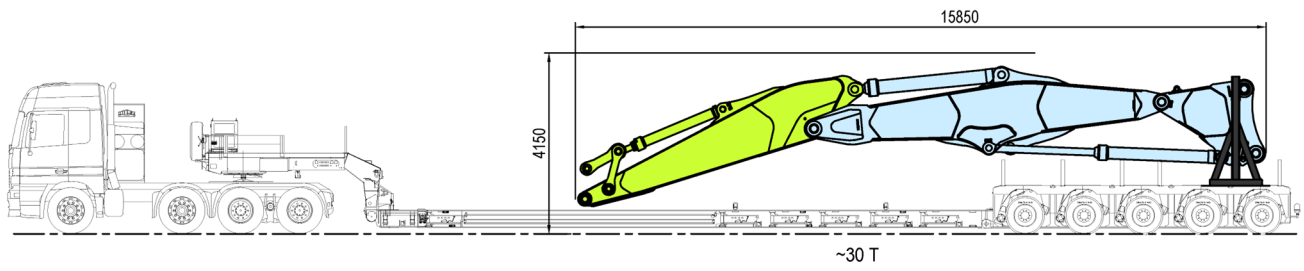
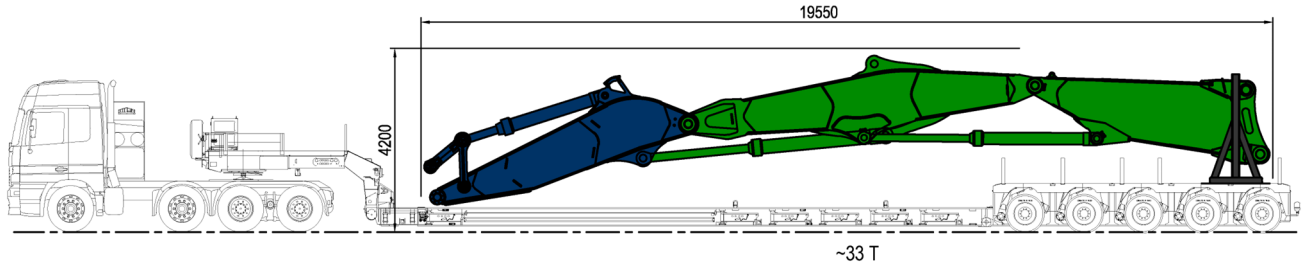

*Specifications are subject to change without notice.  
No rights can be derived from the technical specifications.*

**STC**  
Vosmatenweg 3  
7742 SX Coevorden

The Netherlands  
info@stcbv.nl  
+31 (0)524 525 375

stcbv.nl